

Repair

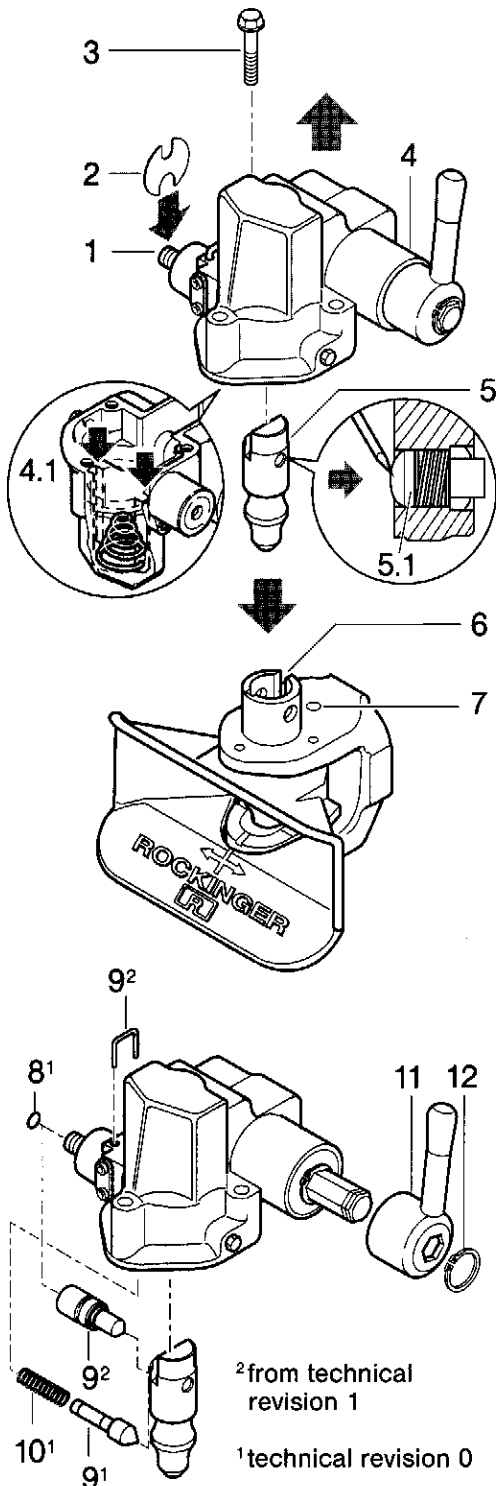

Repair works only by skilled staff!

1. Changing the automatic mechanism and the coupling bolt

Attention: The hand lever axle (16) should not be dismantled!

● Open coupling with the hand lever

Attention! Do not reach into the jaw!

THIS INVOLVES RISK OF AN ACCIDENT!

- Take out lock-control pin (1) until stop slit becomes visible. Careful – do not damage circlip!
- Stop lock-control pin with mounting plate (2) supplied, order no. 65692
- Loosen 3 hexagonal bolts (3)
- Remove automatic mechanism (4) in upward direction
- Gently press automatic mechanism (4) with coupling pin (5) onto work bench (coupling pin 5 will fall off)

When replacing the coupling pin, the safety indicator must be replaced, too. (s. p. 2)

- Insert new coupling pin into the body (lower bush 6)
 - **Attention:** Slit on coupling bolt and upper bush (6) must be aligned.
 - Actuate locking pin (5.1) in coupling pin for control purposes (press outward with screwdriver)
 - Regrease automatic mechanism with grease supplied (see 4.1)
 - Before mounting automatic mechanism, push jaw stop bolt in guide in direction of bore (7)
 - Place automatic mechanism (4) onto upper bush (6), lifting hand lever slightly in the process and guiding throw-up lever into groove of coupling pin underneath retaining pin to enable coupling pin to be raised from throw-up lever, push jaw stop device into bore
 - Press automatic mechanism (4) downwards
 - Secure automatic mechanism (4) gently with screws (3)
 - Remove mounting plate (2) at lock-control pin (1)
 - Press hand lever gently upwards: check lock-control pin for fouling (1)
 - Secure automatic mechanism (4) with screws (3)
- Tightening torque: **27 Nm**
Use screws M 8 x 60 DIN 6921, grade 8.8!

2. Changing the lock-control pin / the safety lock

– technical revision 0

Requirement: **automatic mechanism must be dismantled and coupling bolt removed from automatic mechanism (see point 1.)**

- Remove O-ring (8) at lock-control pin (1)
- Take off mounting plate (2)
- Pull out lock-control pin towards interior
- Insert new lock-control pin (9) with new spring (10) and grease
- Secure with circlip (8)
- Insert mounting plate (2) (further: see point 1.)
- from technical revision 1
- Safety shackle is to be bent up and withdrawn
- Safety lock should completely be extracted out of the housing
- The new safety lock is to be inserted
- Insert the new wire bar
- Wire ends of the safety shackle are to be bent over.

Check:

- Press hand lever (11) gently upwards: check safety for fouling

3. Changing the operating lever

- Remove circlip (12) with circlip pliers A1 from hand lever axle
- Dismantle hand lever (11)
- Fit new hand lever
- Secure new circlip with circlip pliers A1 (do not overstretch circlip)

88107 GB 0

As at 06/01
KE 06/01 I 1172/4-GB
Subject to technical changes without prior notice

ROCKINGER

Member of JOST-World

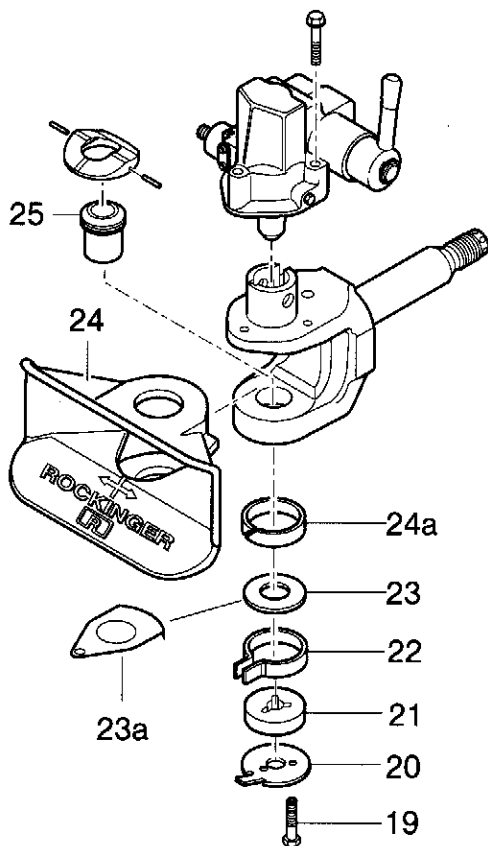
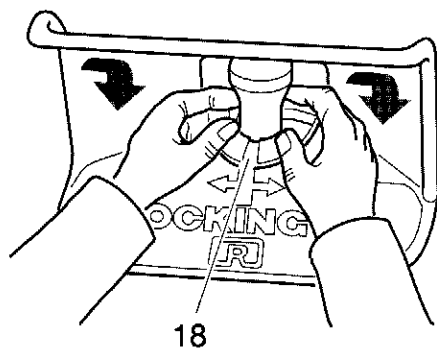
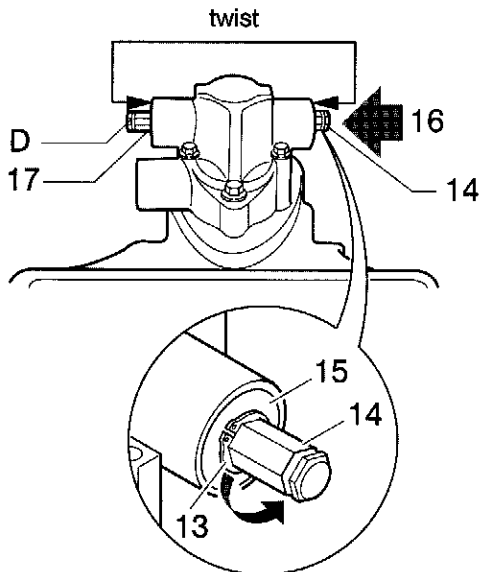

4. Switching the hand lever over to left

(repairset 71079)

- Remove circlip (12) with circlip pliers A1 from hand lever axle (16)
- Dismantle hand lever
- Remove circlip (13) with circlip pliers A1
- Insert new circlip (18 x 1,5) into the groove (14)
- Clamp bearing washers (15) with suitable assembling tool (see illustr.) on left and right
- Knock hand lever axle (16) through carefully
- Dismount spacer (D)
- Remove circlip (17) with circlip pliers A1
- Insert new circlip (18 x 1,5) inside position
- Push hand lever into position
- Secure new circlip (18 x 1,5) with circlip pliers A1 (take care to ensure interference fit)

5. Changing the support ring

- Close coupling: **otherwise risk of accident!**
 - Raise coupling pin with suitable tool **or**
 - Strike hand lever knob briefly in opening direction with heel of hand
- Remove the support ring with the help of the chisel which is to be placed on the lateral recesses
- Lift coupling pin with hand lever
- Take out support ring
- Clean support ring surface and groove (as far as old versions are concerned the spring ring should be removed)
- Fit new support ring (with position marking 18 facing forwards)
- Both slot pins in the support ring must be knocked into laterally

6. Changing the jaw

- Close coupling (see point 5.).
- Loosen 3 screws (19) on base plate (20)
- Remove bottom part with guide bush (21), spring (22) and washer (23) or transmitter disk (23a) for pivoting-angle alarm system
- Raise coupling pin with hand lever and lift out jaw (24)
- Insert new jaw (support ring 24a is mounted in the jaw)
- Upward and downward support wear are to be greased
- Proceed with assembly in reverse sequence (pay attention to bore alignment; insert transmitter disk 23a in correct position)
- When inserting screws, jaw must be located in central position (spring surrounds retaining pin on jaw)
- Opening coupling: Jaw lock should be inserted
- Tighten screws (19)
- **Tightening torque: 30 Nm**
- Please, check the lock and movement of the jaw.

7. Changing the lower bush

- Dismantle coupling from crossbar.
- Disassemble automatic mechanism with coupling pin, jaw and support ring
- Squeeze out bush (25)
- Press in new bush, facing right direction
- Re-assemble and mount coupling; check function

RO*500: Replacement of the bearing parts (repairset) see mounting p. 1171